

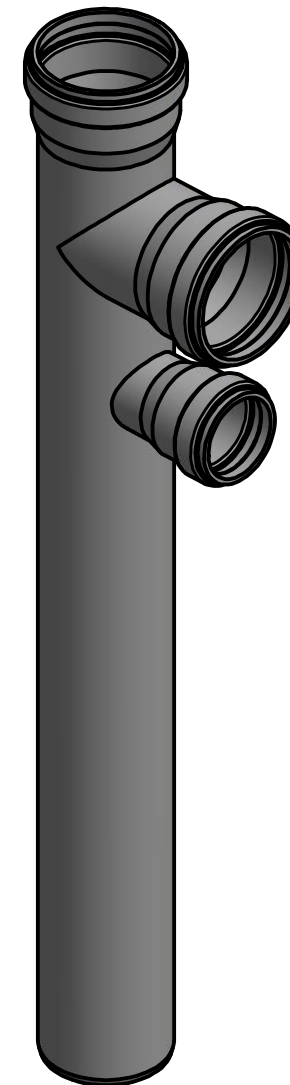

A-A ( 1 : 5 )

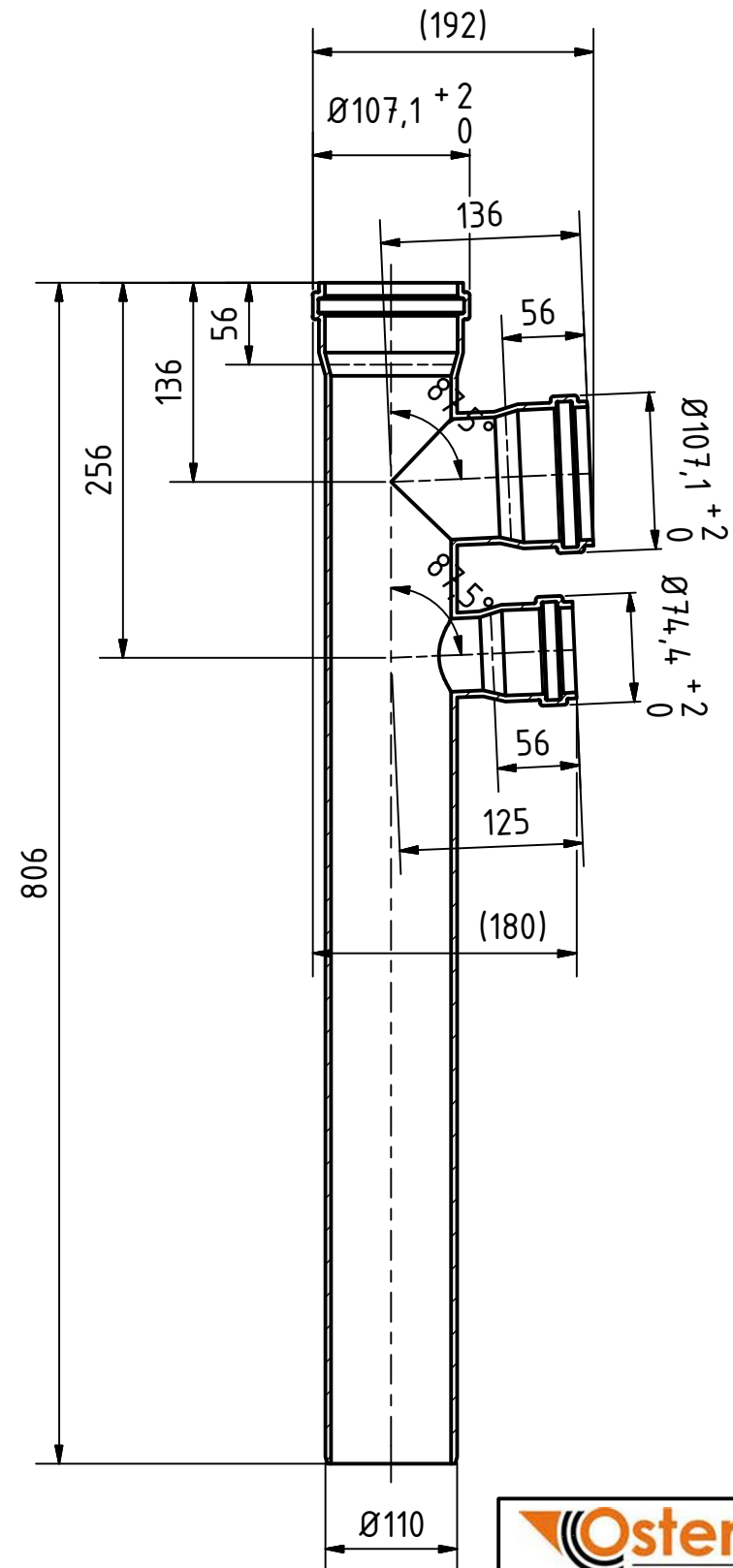

|  |            |                       |      |                 |  |  |  |  |
|--|------------|-----------------------|------|-----------------|--|--|--|--|
|   |            | Maße nach Z-42.1-217  |      | Art.Nr.: 334670 |  | Maßstab 1:5                                  |  |  |
|  |            |                       |      | Material: PP-MD |  |  |  |  |
|  |            | Datum                 |      | Name            |  | <h1>Skolan Safe</h1>                         |  |  |
|  |            | Gezeichnet 16.07.2018 |      | A.Schmedes      |  |  |  |  |
|  |            | Kontroll.             |      |                 |  |  |  |  |
| Status   | Änderungen | Datum                 | Name | Norm            |  |  |  |  |
| Gebr. Ostendorf Kunststoffe GmbH<br>Rudolf-Diesel-Str. 6-8<br>D-49377 Vechta<br>verkauf@ostendorf-kunststoffe.com<br>www.ostendorf-kunststoffe.com |            |                       |      |                 |  | SKOLANsafe Duschkoppelabzweig DN/OD 90/90/58 |  | 1  |
|  |            |                       |      |                 |  |  |  | Schutzvermerk nach DIN ISO 16016 beachten! |